

SC800 PARTS LIST

ITEM #	PART #	QTY	DESCRIPTION
1	800-0135	1	SC800 BASIC MACHINE
2	800-0124	1	SHREDDER HOPPER WELDMENT
3	900-0073	1	FLEX GUARD
4	800-0026	3	PUSH BUTTONS
5	800-0021	2	HANDLE-SHREDDER HOPPER
6	500-0041	2	HANDLE GRIP
7	500-0068	4	VIBRATION DAMPENERS
8	704-0152	1	CHIPPER TUBE WELDMENT
9	804-0033	1	CHIPPER CHUTE COVER
10	804-0031	1	CHIPPER CHUTE TOP FLANGE
11	030-0502	1	ENGINE
12	030-0164	1	CLUTCH
13	800-0024	1	BELT GUARD ASSEMBLY
14	500-0038	1	PULLEY
15	030-0277	1	4H420BELT (CHECK SIZE ON BELT BEFORE ORDERING)
16	500-0057	1	BELT TENSIONER
17	800-0012	1	BAFFLE PLATE
18	800-0013	4	SCREEN AND BAFFLE ROD
19	800-0015	1	SCREEN WITH 1" HOLES
20	800-0031	2	PIPE SPACER
22	800-0145	1	FRONT FOOT
23	804-0020	1	AXLE
24	908-0060	2	AXLE BRACKET
25	703-0108	2	4.10/3.50 X 4" WHEEL
26	090-0457	2	PUSH NUT CAPS
27	500-0031	1	1/4" X 1/4" X 1" KEY
28	090-0066	4	5/16-18 X 3/4" HHCS PLTD.
29	090-0089	6	5/16-18 X 1-1/4" HHCS PLTD.
30	090-0090	6	5/16-18 X 1-1/2" HHCS PLTD.
31	090-0415	1	5/16-18 X 8" HHCS BLK.
32	090-0391	2	5/16-18 X 8" HHCS PLTD.
33	090-0233	13	5/16 FLATWASHER
34	090-0418	2	5/16-18 WHIZLOCK
35	090-0460	23	5/16-18 NYLOCK NUT
36	090-0021	1	3/8-24 X 1-1/4" HHCS
37	090-0228	1	3/8 LOCKWASHER
38	080-0053	2	5/16-18 X 5/16" SET SCREW W/ NYLON PATCH
39	100-0015	4	COTTER PIN
40	090-0512	4	RIVET 3/16" X 13/32"
41	804-0018	1	WASHER
42	703-0424	1	1/4" X 1/4" X 2" KEY
43	090-0024-2	1	SHIM
44	020-0000	1	RETAINING RING

SC800 MAIN ASSEMBLY

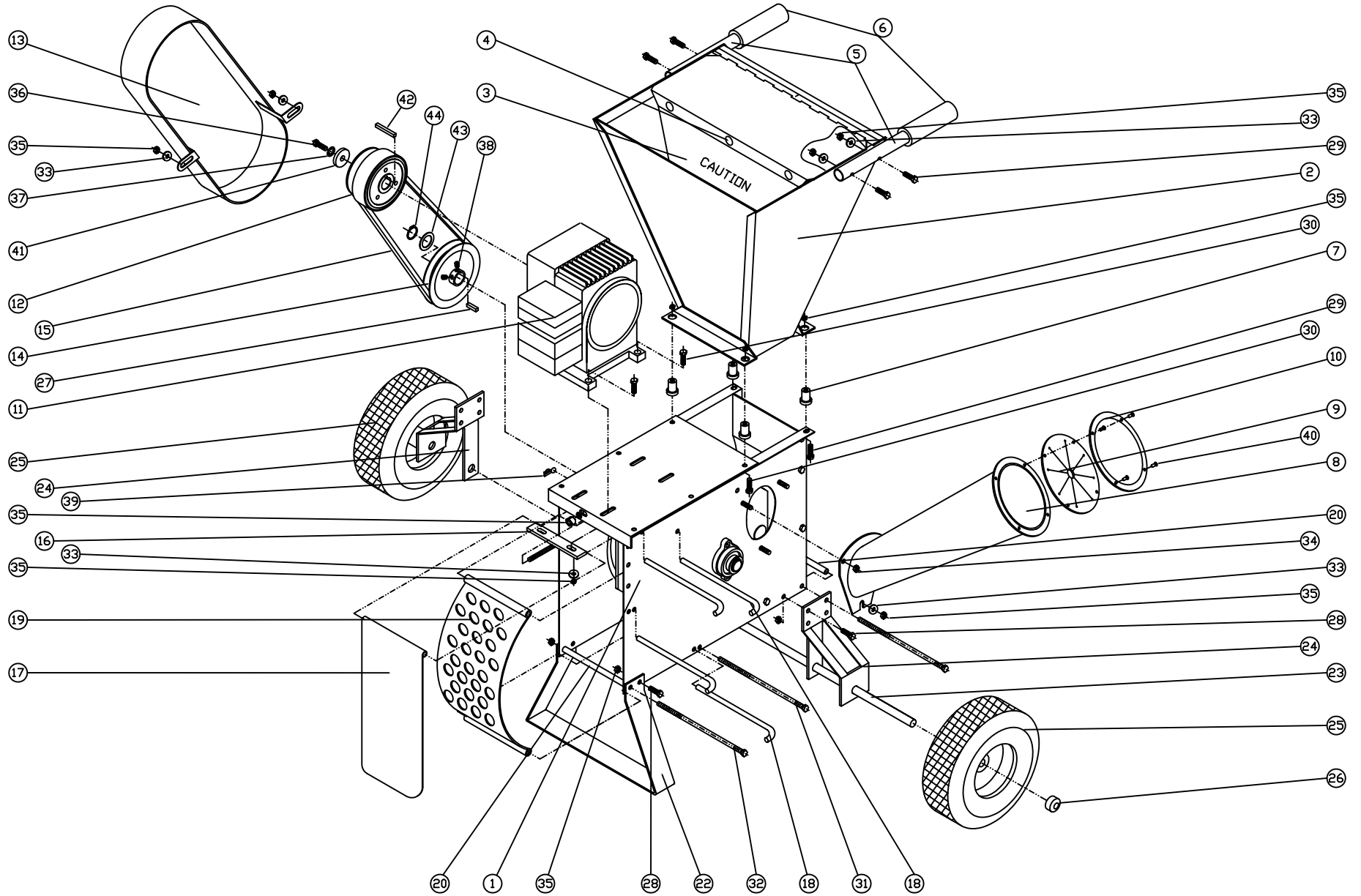

SC800
MAIN ASSEMBLY

**800-0135 SC800 BASIC MACHINE
PARTS LIST**

ITEM #	PART #	QTY	DESCRIPTION
1	800-0120	1	ROTOR ASSEMBLY
2	800-0064	1	CHIPPER SIDE PLATE WELDMENT
3	800-0137	1	DRIVE SIDE PLATE WELDMENT
4	800-0010	1	SCROLL WELDMENT
5	800-0134	1	TOP PLATE
6	030-0055	2	2 BOLT, 1" BEARING
7	090-0024-2	1	SHIM
8	020-0000	1	1" RETAINING RING
9	090-0066	4	5/16-18 X 3/4" HHCS
10	090-0088	4	5/16-18 X 1" HHCS
11	090-0089	8	5/16-18 X 1 1/4" HHCS
12	090-0415	1	5/16-18 X 8" HHCS - BLACK
13	090-0048	17	5/16-18 GRIPCO LOCKNUT
14	913-0210	1	KNIFE ACCESS DOOR
15	090-0162	4	10-32 X 3/8 SELF TAPPING SCREWS

**800-0120 – SC800 ROTOR ASSEMBLY
PARTS LIST**

ITEM #	PART #	QTY	DESCRIPTION
1	800-0057	1	ROTOR WELDMENT
2	900-0100-2	4	HAMMER ROD
3	500-0008	16	HAMMERS
4	500-0010	4	SPACER – 5/16"
5	500-0012	20	SPACER – 5/8"
6	500-0011	2	SPACER – 7/8"
7	500-0072	2	SPACER – 1 1/2"
8	030-0498	1	KNIFE
9	090-0413	3	5/16-18 X 1" FHSCS
10	090-0460	3	5/16-18 NYLOCK NUT
11	090-0479	4	SHIM WASHER
12	030-0153	4	GROOVE PIN

SC800 BASIC MACHINE ASSEMBLY

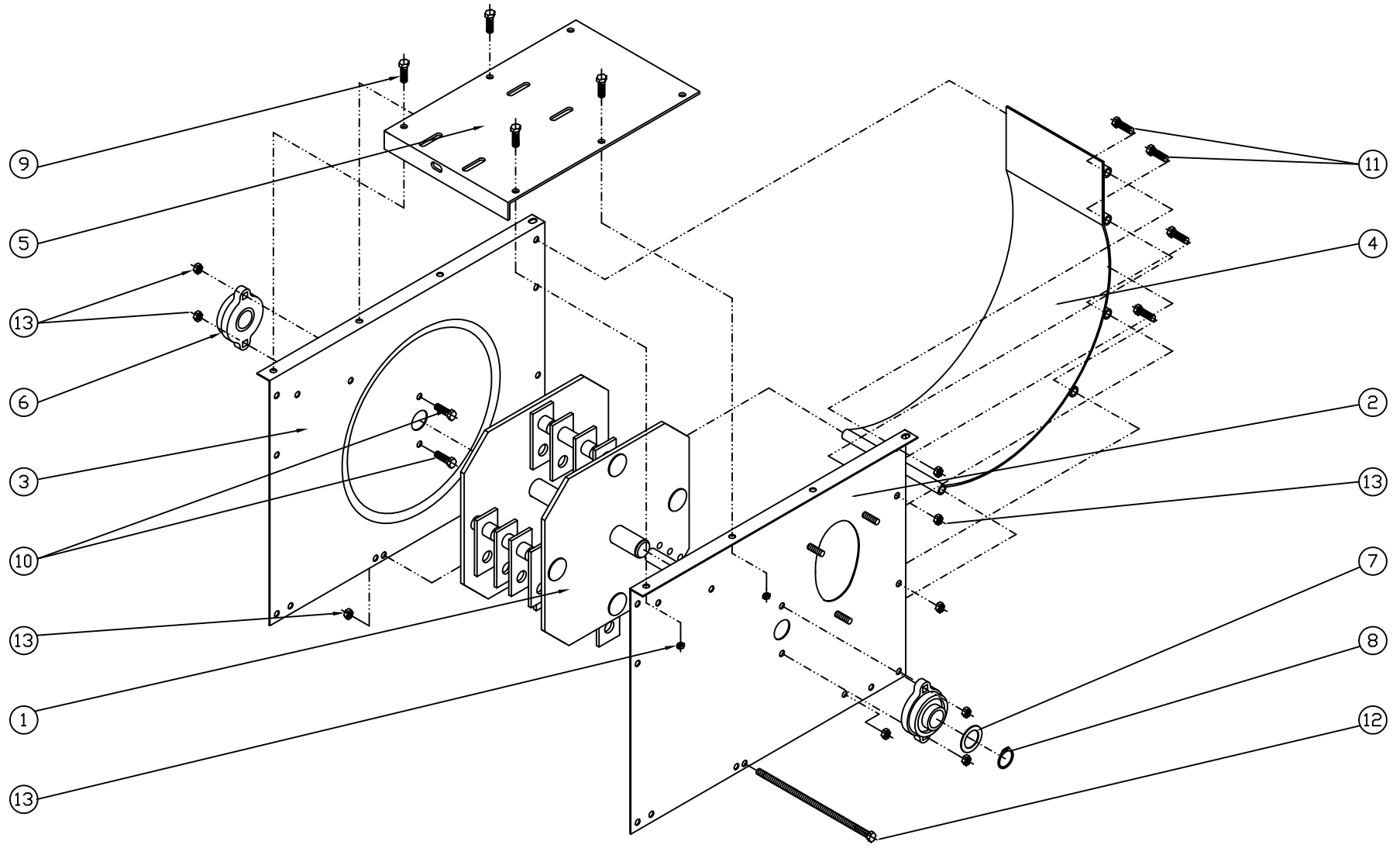

SC800
BASIC MACHINE ASSEMBLY

SC800 ROTOR ASSEMBLY

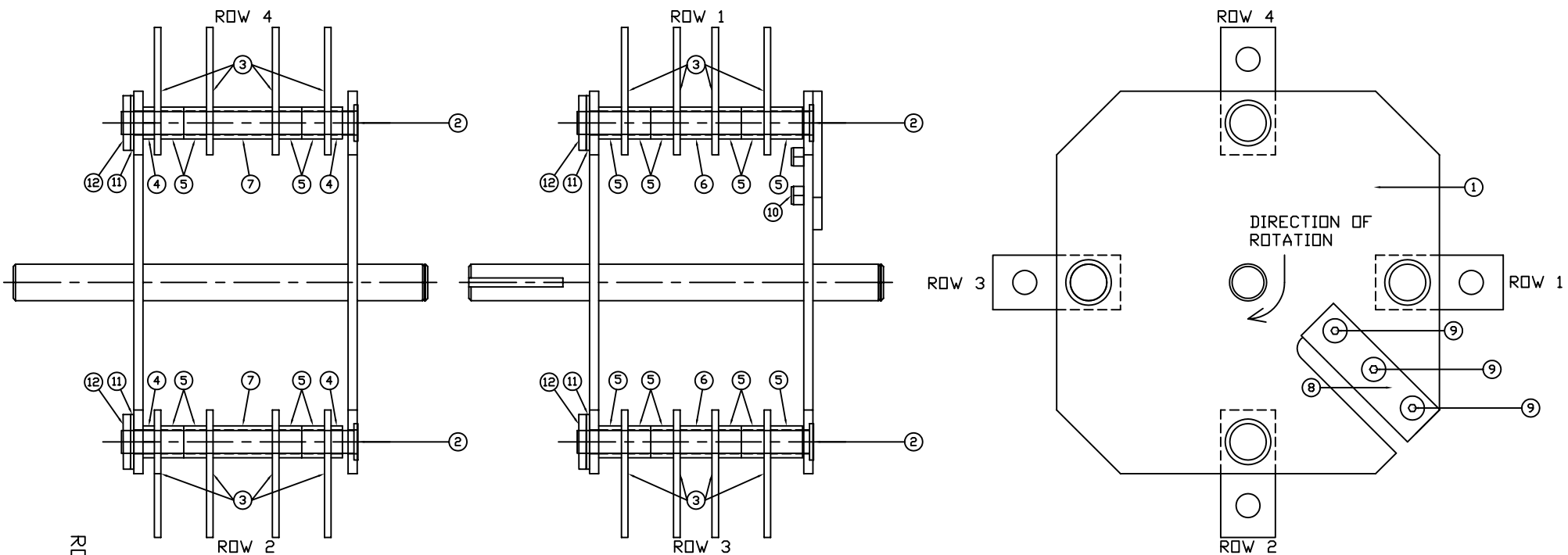

SC800
ROTOR ASSEMBLY